



## Features

- Up to 1.25Gbps bi-directional fiber link
- Compliant with IEEE802.3z Gigabit Ethernet standard
- Compliant with 1x Fibre Channel standard
- Compliant with SFP MSA
- Compliant with SFF8472 diagnostic monitoring interface for Optical Transceivers (DOM)
- 1310nm FP transmitter
- SMF 10km point-to-point transmission
- Duplex LC receptacle connector
- 2-wire I2C interface for management and diagnostic monitor
- ISO9001 and RoHS Compliant

## Application

- 1000Base-LX Ethernet
- 1x Fibre Channel
- Other Optical Link

## Ordering Information

PART NO.	TX	RX	DISTANCE	DOM	TEMPERATURE
GL1250-SFP-LX10	1310 nm	1310nm	SMF 10km	Support	0~70°C
GL1250-SFP-LX10-I	1310 nm	1310nm	SMF 10km	Support	-40~85°C

**GallopLight Technology Co., Ltd.**

2F, No.181, Zhouzi St., Neihu District, Taipei 11493, Taiwan (R.O.C)

TEL : +886-2-2799-7121 FAX : +886-2-2799-7181 Sales@galloplight.com



# 1000Base-LX SFP Optical Transceiver Single-Mode 1310nm, 10km, DOM



## Absolute Maximum Ratings

PARAMETER	SYMBOL	MIN	MAX	UNITS	NOTE
Storage Temperature	$T_s$	-40	+85	°C	
Supply Voltage	$V_{cc}$	-0.5	4.0	V	
Storage Relative Humidity	$RH$	5	95	%	

## Recommended Operating Conditions

PARAMETER	SYMBOL	MIN	TYP.	MAX	UNITS	NOTE
Case Operating Temperature	$T_c$	0	---	70	°C	GL1250-SFP-LX10
		-40	---	85	°C	GL1250-SFP-LX10-I
Supply Voltage	$V_{cc}$	3.13	3.3	3.47	V	
Supply Current	$I_{TX} + I_{RX}$	---		260	mA	
Power Consumption	$P$			0.9	W	

**GallopLight Technology Co., Ltd.**

2F, No.181, Zhouzi St., Neihu District, Taipei 11493, Taiwan (R.O.C)

TEL : +886-2-2799-7121 FAX : +886-2-2799-7181 Sales@galloplight.com



# 1000Base-LX SFP Optical Transceiver Single-Mode 1310nm, 10km, DOM



## Transmitter Electro-optical Interface

PARAMETER	SYMBOL	MIN	TYP.	MAX	UNITS	NOTE
Data Rate	DR		1.25		Gbps	
Optical Output Power	P <sub>O</sub>	-9		-3	dBm	1
Optical Extinction Ratio	ER	9			dB	
Center Wavelength	$\lambda_c$	1270	1310	1355	nm	
Spectral Width (RMS)	$\Delta\lambda$			3.5	nm	
Relative Intensity Noise	RIN			-120	dB/Hz	
Output Eye		Compliant with IEEE802.3z				
Differential Input Voltage Swing	V <sub>DIFF</sub>	400		2000	mV	
Differential Input Impedance	Z <sub>d</sub>	90	100	110	$\Omega$	
Tx_Fault – High (Tx Fault)	V <sub>Fault_H</sub>	2.0		V <sub>cc</sub>	V	
Tx_Fault – Low (Tx Normal)	V <sub>Fault_L</sub>	V <sub>ee</sub>		0.8	V	
Tx_Disable – High (Tx Off)	V <sub>Disable_H</sub>	2.0		V <sub>cc</sub>	V	
Tx_Disable – Low (Tx On)	V <sub>Disable_L</sub>	V <sub>ee</sub>		0.5	V	

Note 1: Coupling into a 9/125 $\mu$ m single-mode fiber.

**GallopLight Technology Co., Ltd.**

2F, No.181, Zhouzi St., Neihu District, Taipei 11493, Taiwan (R.O.C)

TEL : +886-2-2799-7121 FAX : +886-2-2799-7181 Sales@galloplight.com



# 1000Base-LX SFP Optical Transceiver Single-Mode 1310nm, 10km, DOM



## Receiver Electro-optical Interface

PARAMETER	SYMBOL	MIN	TYP.	MAX	UNITS	NOTE
Data Rate	DR		1.25		Gbps	
Optical Input Power-maximum	P <sub>IN</sub>			-3	dBm	
Receiver Sensitivity	P <sub>IN</sub>			-21	dBm	1
Operating Center Wavelength	λ <sub>c</sub>	1260		1620	nm	
Optical Return Loss	ORL	12			dB	
Loss of Signal (LOS) - Asserted	P <sub>A</sub>	-35			dBm	
Loss of Signal (LOS) - De-asserted	P <sub>D</sub>			-22	dBm	
Differential Output Voltage Swing	V <sub>DIFF</sub>	500		2000	mV	
Differential Input Impedance	Z <sub>d</sub>	90	100	110	Ω	
LOS Signal Output Voltage - Low	LOS <sub>VL</sub>	V <sub>ee</sub>		0.5	V	
LOS Signal Output Voltage - High	LOS <sub>VH</sub>	2.4		V <sub>cc</sub>	V	

Note 1: With BER better than or equal to  $1 \times 10^{-12}$ , measured in the center of the eye opening with 1.25Gbps, PRBS 2<sup>7</sup>-1

**GallopLight Technology Co., Ltd.**

2F, No.181, Zhouzi St., Neihu District, Taipei 11493, Taiwan (R.O.C)

TEL : +886-2-2799-7121 FAX : +886-2-2799-7181 Sales@galloplight.com



## Pin Assignment

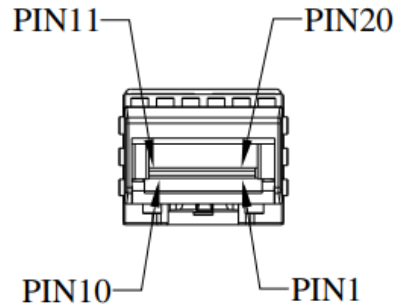

PIN NO.	PIN NAME	FUNCTION	NOTE
1	VeeT	Transmitter Ground	
2	TX Fault	Transmitter Fault Indication	
3	TX Disable	Transmitter Disable	
4	MOD_DEF 2	Module Definition 2 (Serial Data Signal)	SDA
5	MOD_DEF 1	Module Definition 1 (Serial Data Clock)	SCL
6	MOD_DEF 0	Module Definition 0	TTL Low
7	RS	Rate Select	No used
8	Rx_LOS	Loss of Signal	Open collector
9	VeeR	Receiver Ground	
10	VeeR	Receiver Ground	
11	VeeR	Receiver Ground	
12	RD-	Inv. Receiver Data Out (AC coupled)	
13	RD+	Receiver Data Out (AC coupled)	
14	VeeR	Receiver Ground	
15	V <sub>CC</sub> R	Receiver Power	
16	V <sub>CC</sub> T	Transmitter Power	
17	VeeT	Transmitter Ground	
18	TD+	Transmitter Data In (AC coupled)	
19	TD-	Inv. Transmitter Data In (AC coupled)	
20	VeeT	Transmitter Ground	

**GallopLight Technology Co., Ltd.**

2F, No.181, Zhouzi St., Neihu District, Taipei 11493, Taiwan (R.O.C)

TEL : +886-2-2799-7121 FAX : +886-2-2799-7181 Sales@galloplight.com



## Digital Diagnostic Memory Map

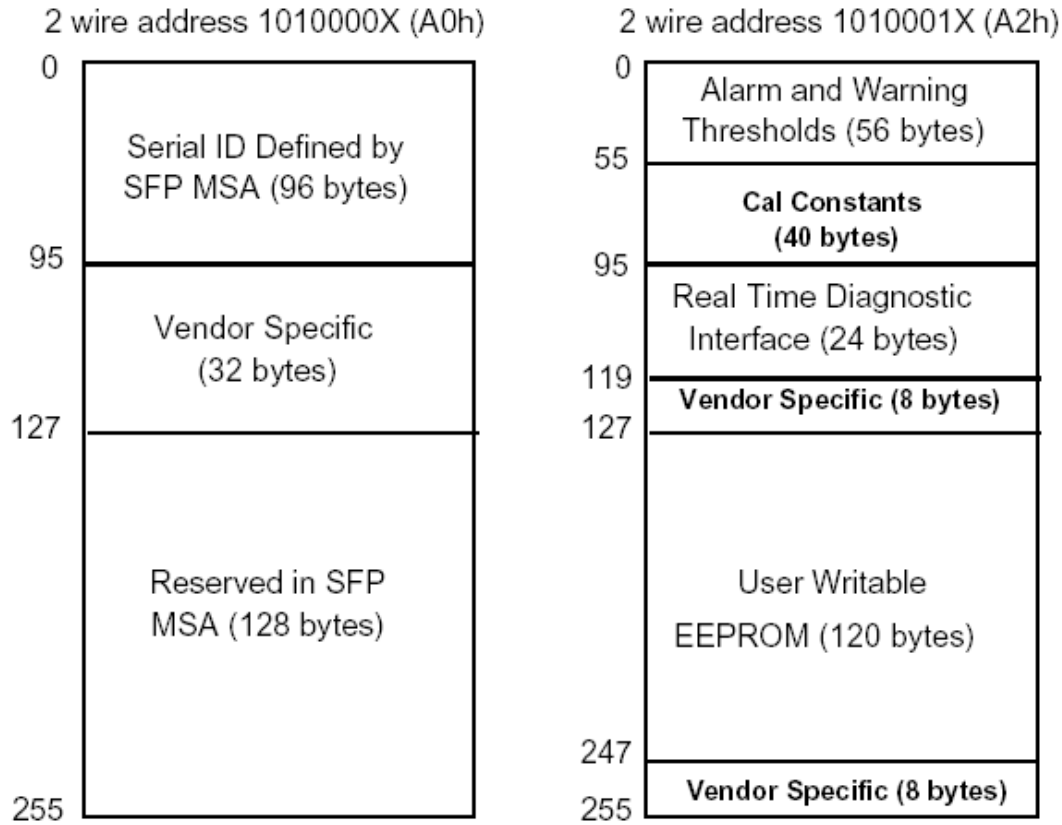

## Digital Diagnostic Monitoring Characteristics

PARAMETER	SYMBOL	ACCURACY	UNIT	NOTE
Transceiver Temperature	$T_{INT}$	$\pm 3$	$^{\circ}C$	
Transceiver Supply Voltage	$V_{INT}$	$\pm 3$	%	
TX Bias Current	$I_{BIAS}$	$\pm 10$	%	
TX Output Power	$P_{TX}$	$\pm 3$	dB	
RX Received Optical Power	$P_{RX}$	$\pm 3$	dB	



**Mechanical Dimensions** (All dimensions are  $\pm 0.20\text{mm}$  Unless Otherwise Specified, Unit: mm):

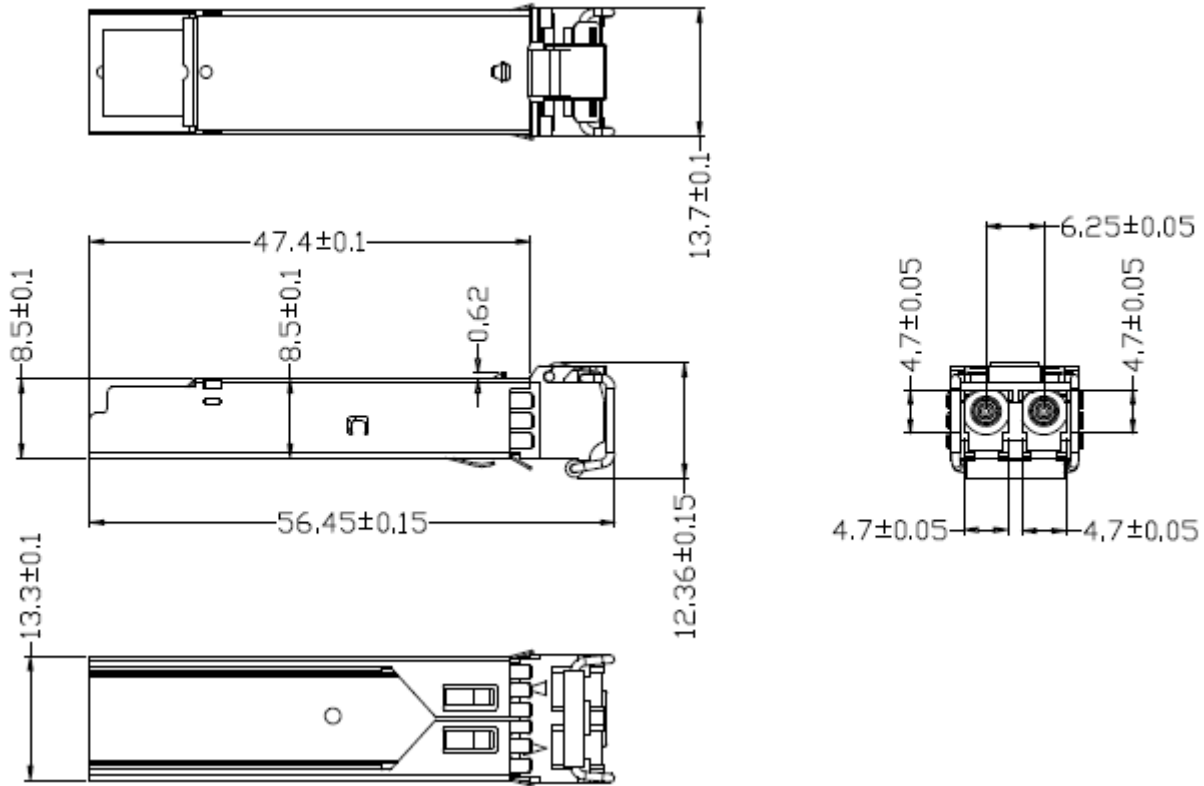

**GallopLight Technology Co., Ltd.**

2F, No.181, Zhouzi St., Neihu District, Taipei 11493, Taiwan (R.O.C)

TEL : +886-2-2799-7121 FAX : +886-2-2799-7181 Sales@galloplight.com