



Features

- Four-channel full-duplex transceiver module
- Up to 25.78125Gbps data rate per channel
- Compliant with IEEE802.3ba 100GBase-ER4 Ethernet standard
- Compliant with IEEE802.3bm CAUI-4 Interface
- Compliant with QSFP28 MSA SFF-8636
- Built-in diagnostic monitoring interface for Optical Transceivers (DOM)
- Cooled DFB LAN-WDM
- 4 channels optical Mux/DeMux design
- Built-in quad CDR
- SMF 40km point-to-point transmission
- Support Hot Pluggable
- Duplex LC connector
- 2-wire I2C interface for management and diagnostic monitor
- RoHS Compliant

Application

- 100GBase-ER4 100G Ethernet
- Data Center Application

Ordering Information

PART NO.	TX	RX	DISTANCE	DOM	TEMPERATURE
GL100G-QSFP-ER4	1295.56 nm	1295.56 nm	SMF 40km	Support	0~70°C
	1295.56 nm	1295.56 nm			
	1295.56 nm	1295.56 nm			
	1295.56 nm	1295.56 nm			

GallopLight Technology Co., Ltd.

2F, No.181, Zhouzi St., Neihu District, Taipei 11493, Taiwan (R.O.C)

TEL : +886-2-2799-7121 FAX : +886-2-2799-7181 Sales@galloplight.com



100GBase-ER4 QSFP28 Optical Transceiver Single Mode 1300nm LWDM, 40km, DOM



Absolute Maximum Ratings

PARAMETER	SYMBOL	MIN	MAX	UNITS	NOTE
Storage Temperature	T_s	-40	+85	°C	
Supply Voltage	V_{cc}	-0.5	4.0	V	
Storage Relative Humidity	RH	5	95	%	

Recommended Operating Conditions

PARAMETER	SYMBOL	MIN	TYP.	MAX	UNITS	NOTE
Case Operating Temperature	T_C	0	---	70	°C	
Supply Voltage	V_{cc}	3.13	3.3	3.47	V	
Supply Current	$I_{TX} + I_{RX}$	---		1360	mA	
Power Consumption	P			4.5	W	

GallopLight Technology Co., Ltd.

2F, No.181, Zhouzi St., Neihu District, Taipei 11493, Taiwan (R.O.C)

TEL : +886-2-2799-7121 FAX : +886-2-2799-7181 Sales@galloplight.com



Transmitter Electro-optical Interface

PARAMETER	SYMBOL	MIN	TYP.	MAX	UNITS	NOTE
Data Rate, per Lane	DR		25.78125		Gbps	
Total Average Optical Output Power	P _{O-TAVG}			+10.0	dBm	
Average Optical Output Power, per Lane	P _{O-AVG}	-2.5		+4.0	dBm	1
Optical Output Power, per Lane (OMA)	P _{O-OMA}	+0.1		+4.5	dBm	
Optical Output Power in OMA minus Transmitter & Dispersion Penalty (TDP), per Lane	P _{O-TP}	-0.65			dB	
Transmitter Dispersion Penalty, per Lane	TDP			2.5	dB	
Difference in Launch Power between any two Lanes (OMA)				3.6	dB	
Optical Extinction Ratio	ER	4.5			dB	
Operating Center Wavelength	λ _{L0}	1294.53	1295.56	1296.59	nm	
	λ _{L1}	1299.02	1300.05	1301.09	nm	
	λ _{L2}	1303.54	1304.58	1305.63	nm	
	λ _{L3}	1308.09	1309.14	1310.19	nm	
Spectral Width (-20dB)	Δλ			1	nm	
Side Mode Suppression Ratio	SMSR	30			dB	
Eye Mask {X1,X2,X3,Y1,Y2,Y3}		{0.25, 0.4, 0.45, 0.25, 0.28, 0.4}				2
Output Power @Tx_Dis Asserted	P _{OFF}			-30	dBm	
Relative Intensity Noise	RIN			-130	dB/Hz	
Optical Return Loss Tolerance				20	dB	
Transmitter Reflectance				-12	dB	
Differential Input Voltage Swing	V _{DIFF}			900	mV	
Differential Input Impedance	Z _d	90	100	110	Ω	
LVTTL I/O – High	V _{IO,H}	2.0		V _{cc}	V	
LVTTL I/O – Low	V _{IO,L}	V _{ee}		0.8	V	

Note 1: Even if the TDP<1dB, the OMA min must exceed the minimum value specified here.

Note 2: Hit ratio 5x10⁻⁵ hits per sample.

GallopLight Technology Co., Ltd.

2F, No.181, Zhouzi St., Neihu District, Taipei 11493, Taiwan (R.O.C)

TEL : +886-2-2799-7121 FAX : +886-2-2799-7181 Sales@galloplight.com



Receiver Electro-optical Interface

PARAMETER	SYMBOL	MIN	TYP.	MAX	UNITS	NOTE
Data Rate, per Lane	DR		25.78125		Gbps	
Damage Threshold, per Lane	TH _D	-3.0			dBm	1
Total Average Optical Receive Power		-7.9		+1.12	dBm	
Average Optical Receive Power, per Lane	P _{I-AVG}	-20		-4.9	dBm	
Optical Receive Power (OMA), per Lane	P _{I-OMA}			-1.9	dBm	
Receiver Sensitivity (OMA), per Lane	SEN _{-OMA1}			-14.65	dBm	2
Receiver Sensitivity (OMA), per Lane	SEN _{-OMA2}			-18.65	dBm	3
Difference in Receive Power between any two Lanes (OMA)				3.6	dB	
Receiver Reflectance				-26	dBm	
Operating Center Wavelength	λ _{L0}	1294.53	1295.56	1296.59	nm	
	λ _{L1}	1299.02	1300.05	1301.09	nm	
	λ _{L2}	1303.54	1304.58	1305.63	nm	
	λ _{L3}	1308.09	1309.14	1310.19	nm	
Loss of Signal (LOS) - Asserted	LOS _A	-26			dBm	
Loss of Signal (LOS) - De-asserted	LOS _D			-24	dBm	
Loss of Signal (LOS) - Hysteresis	LOS _H	0.5			dB	
Differential Output Voltage Swing	V _{DIFF}	300		850	mV	
Differential Input Impedance	Z _d	90	100	110	Ω	

Note 1: The receiver shall be able to tolerate, without damage, continuous exposure to a modulated optical input signal having this power level on one lane. The receiver does not have to operate correctly at this input power.

Note 2: Measured with conformance test signal at receiver input for BER= 1x10⁻¹²

Note 3: Measured with conformance test signal at receiver input for BER= 5x10⁻⁵

GallopLight Technology Co., Ltd.

2F, No.181, Zhouzi St., Neihu District, Taipei 11493, Taiwan (R.O.C)

TEL : +886-2-2799-7121 FAX : +886-2-2799-7181 Sales@galloplight.com



Pin Assignment

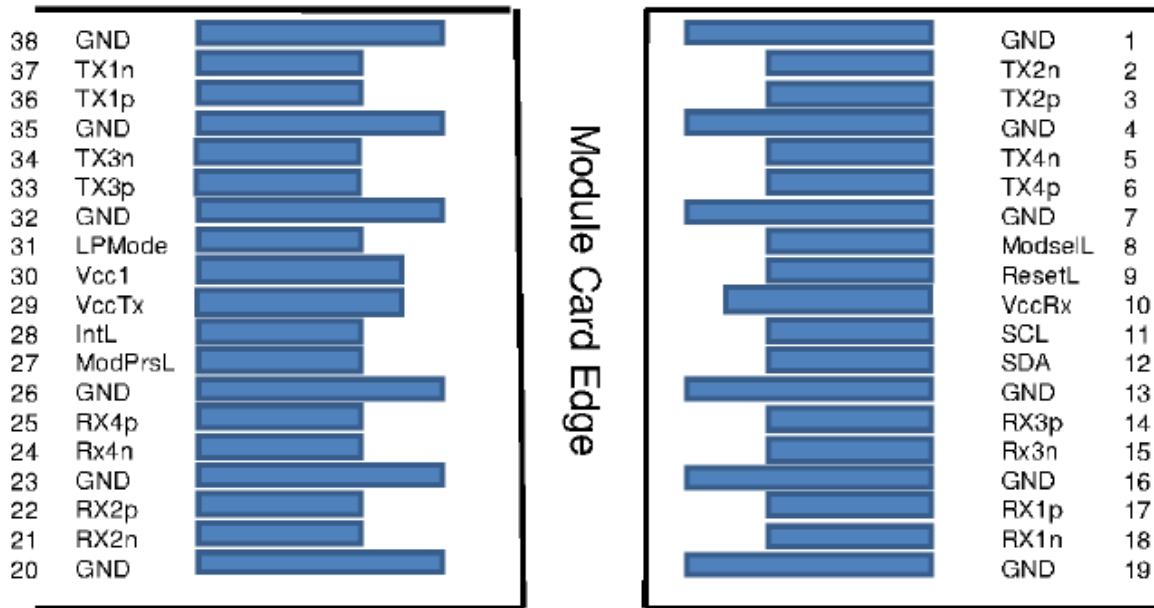

Top Side
Viewed From Top

Bottom Side
Viewed From Bottom

PIN NO.	PIN NAME	FUNCTION	NOTE
1	GND	Ground	
2	Tx2n	Transmitter ch#2 Inverted Data Input	CML-I
3	Tx2p	Transmitter ch#2 Non-Inverted Data Input	CML-I
4	GND	Ground	
5	Tx4n	Transmitter ch#4 Inverted Data Input	CML-I
6	Tx4p	Transmitter ch#4 Non-Inverted Data Input	CML-I
7	GND	Ground	
8	ModSelL	Module Select	LVTTL-I
9	ResetL	Module Reset	LVTTL-I
10	VccRx	Receiver +3.3V Power Supply	
11	SCL	2-Wire Serial Interface Clock	LVCOMS-I/O
12	SDA	2-Wire Serial Interface Data	LVCOMS-I/O

GallopLight Technology Co., Ltd.

2F, No.181, Zhouzi St., Neihu District, Taipei 11493, Taiwan (R.O.C)

TEL : +886-2-2799-7121 FAX : +886-2-2799-7181 Sales@galloplight.com



13	GND	Ground	
14	Rx3p	Receiver ch#3 Non-Inverted Data Output	CML-O
15	Rx3n	Receiver ch#3 Inverted Data Output	CML-O
16	GND	Ground	
17	Rx1p	Receiver ch#1 Non-Inverted Data Output	CML-O
18	Rx1n	Receiver ch#1 Inverted Data Output	CML-O
19	GND	Ground	
20	GND	Ground	
21	Rx2n	Receiver ch#2 Inverted Data Output	CML-O
22	Rx2p	Receiver ch#2 Non-Inverted Data Output	CML-O
23	GND	Ground	
24	Rx4n	Receiver ch#4 Inverted Data Output	CML-O
25	Rx4p	Receiver ch#4 Non-Inverted Data Output	CML-O
26	GND	Ground	
27	ModPrsL	Module Present	LVTTL-O
28	IntL	Interrupt	LVTTL-O
29	VccTx	Transmitter +3.3V Power Supply	
30	Vcc1	+3.3V Power Supply	
31	LPMMode	Low Power Mode	LVTTL-I
32	GND	Ground	
33	Tx3p	Transmitter ch#3 Non-Inverted Data Input	CML-I
34	Tx3n	Transmitter ch#3 Inverted Data Input	CML-I
35	GND	Ground	
36	Tx1p	Transmitter ch#1 Non-Inverted Data Input	CML-I
37	Tx1n	Transmitter ch#1 Inverted Data Input	CML-I
38	GND	Ground	

GallopLight Technology Co., Ltd.

2F, No.181, Zhouzi St., Neihu District, Taipei 11493, Taiwan (R.O.C)

TEL : +886-2-2799-7121 FAX : +886-2-2799-7181 Sales@galloplight.com



Digital Diagnostic Memory Map

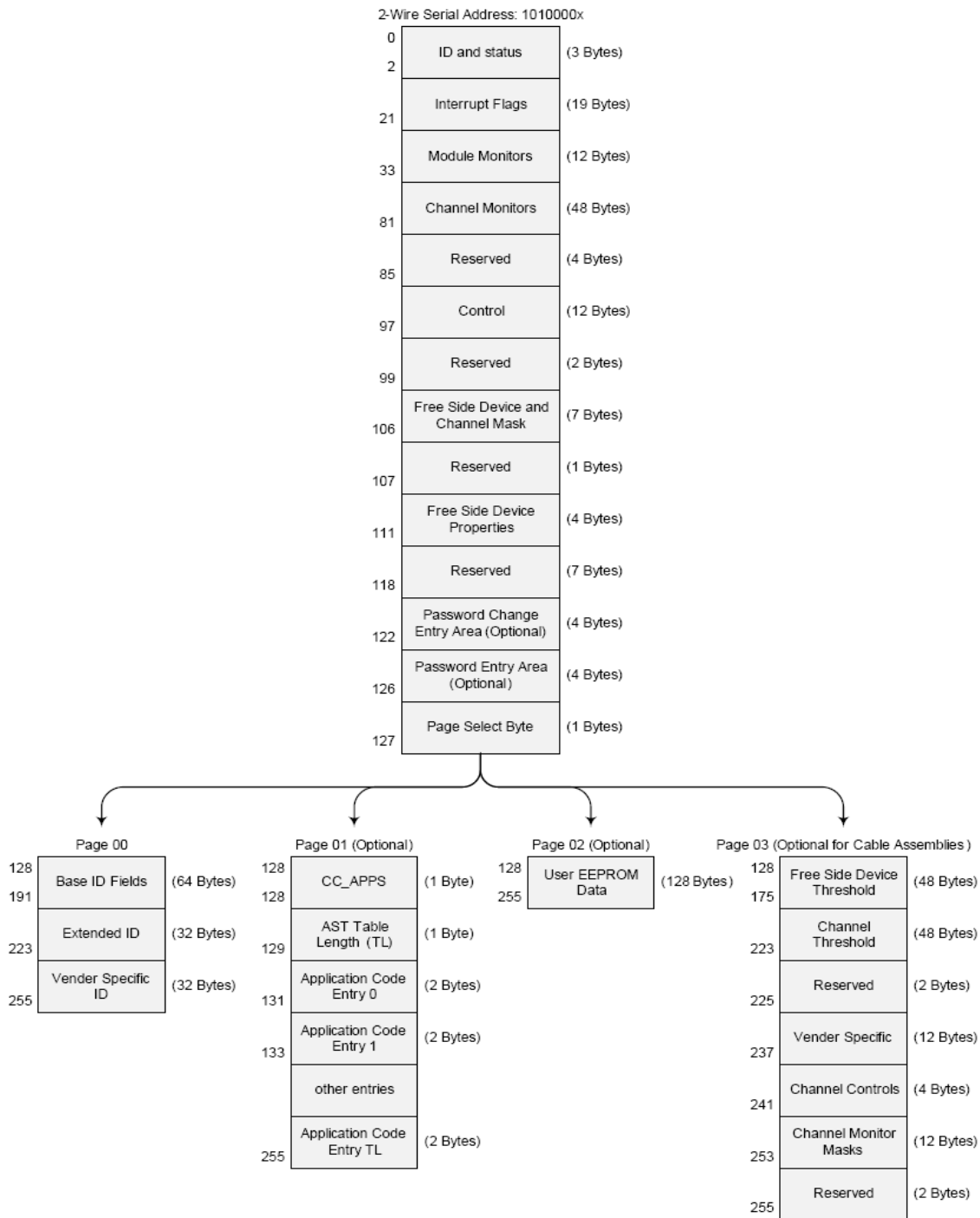

GallopLight Technology Co., Ltd.

2F, No.181, Zhouzi St., Neihu District, Taipei 11493, Taiwan (R.O.C)

TEL : +886-2-2799-7121 FAX : +886-2-2799-7181 Sales@galloplight.com



Digital Diagnostic Monitoring Characteristics

PARAMETER	SYMBOL	ACCURACY	UNIT	NOTE
Transceiver Temperature	T_{INT}	± 3	$^{\circ}C$	
Transceiver Supply Voltage	V_{INT}	± 3	%	
TX Bias Current	I_{BIAS}	± 10	%	
TX Output Power	P_{TX}	± 3	dB	
RX Received Optical Power	P_{RX}	± 3	dB	

Mechanical Dimensions (All dimensions are $\pm 0.20mm$ Unless Otherwise Specified, Unit: mm):

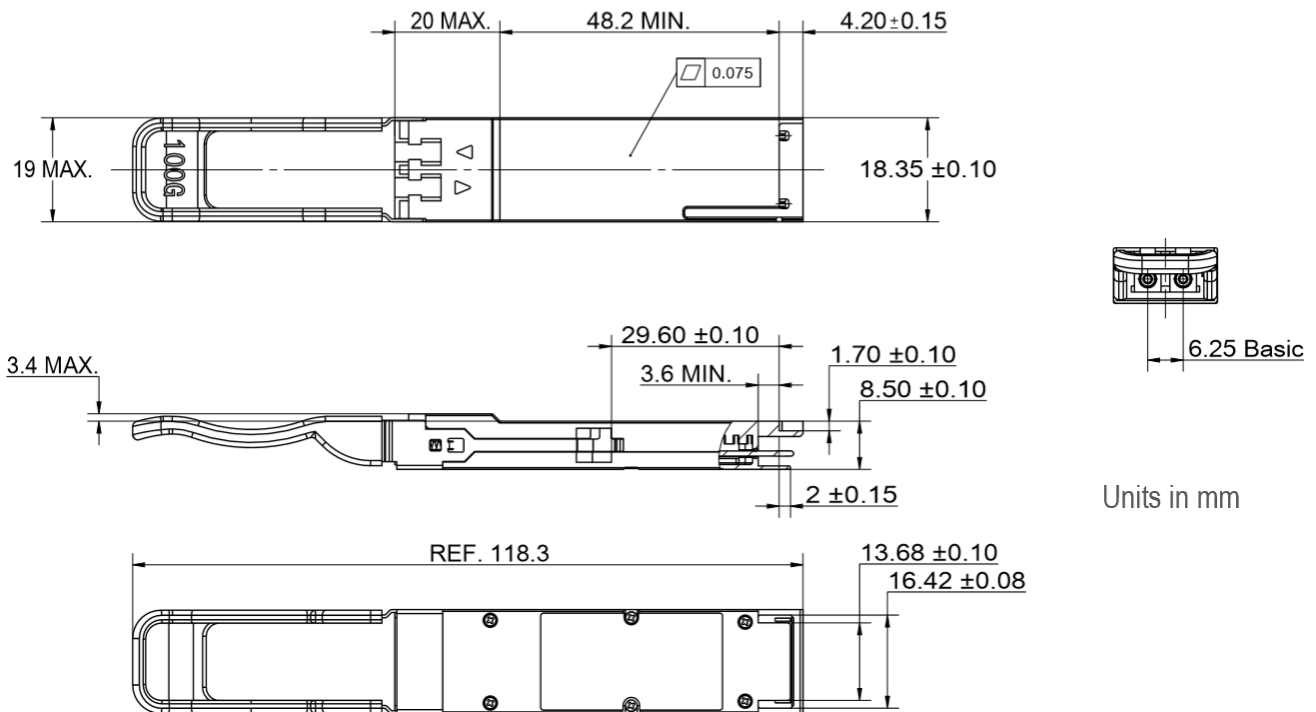

GallopLight Technology Co., Ltd.

2F, No.181, Zhouzi St., Neihu District, Taipei 11493, Taiwan (R.O.C)

TEL : +886-2-2799-7121 FAX : +886-2-2799-7181 Sales@galloplight.com